

AN-1001

Monitoring External Contacts with RTD Inputs of the EPC-2374

Summary

The EPC-2374 provides two standard PT-100 RTD (Resistance Temperature Detector) inputs and 8 optional RTD inputs. Using these inputs, it is possible to monitor external contacts or dry contact outputs from external devices. In addition to monitoring the status of the monitored contacts, the contact state can be used in the EPC-2374 output logic as an “enable” condition.

Determining Contact State

The RTD inputs of the EPC-2374 sense the resistance of the connected temperature detector. Using fixed resistors, the EPC-2374 can be configured to trip above or below a set-point based upon a fixed value. Upon closure of the monitored contact, a second resistor is switched into the RTD input which results in an assertion of the configured RTD input.

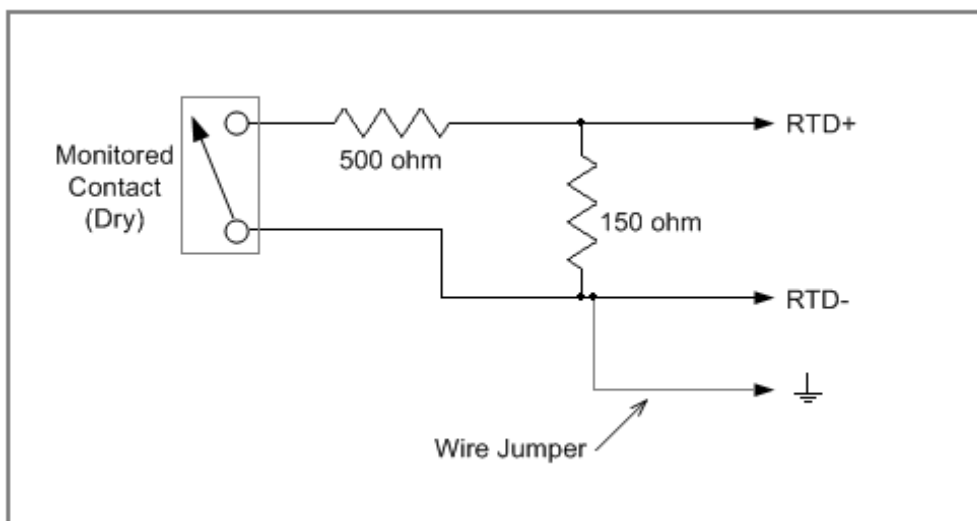

Figure 1: Using resistors to monitor a contact

In Figure 1, a 150 ohm resistor is connected to the RTD input of choice. Since the EPC-2374 supports three-wire RTD inputs, a small jumper wire is required between the negative input and the ground terminal. Refer to the manual for RTD connections.

The 150 ohm resistor will give a temperature reading of 130 degrees C, given the RTD channel is enabled in the set-point manager. Notice in figure 1, the 500 ohm resistor is out of the circuit while the monitored contact is open. Upon the closure of the monitored contact, the resistance seen by the EPC-2374 drops from 150 ohms (approximately 130 degrees C) to 115.38 ohms (approximately 40 degrees C).

The EPC-2374 is configured for a 'trip under' 100 degrees and this change will result in a trip condition of the respective RTD channel.

The trip condition detected above may be used as an "enable" signal in the EPC-2374 output manager's logic engine.

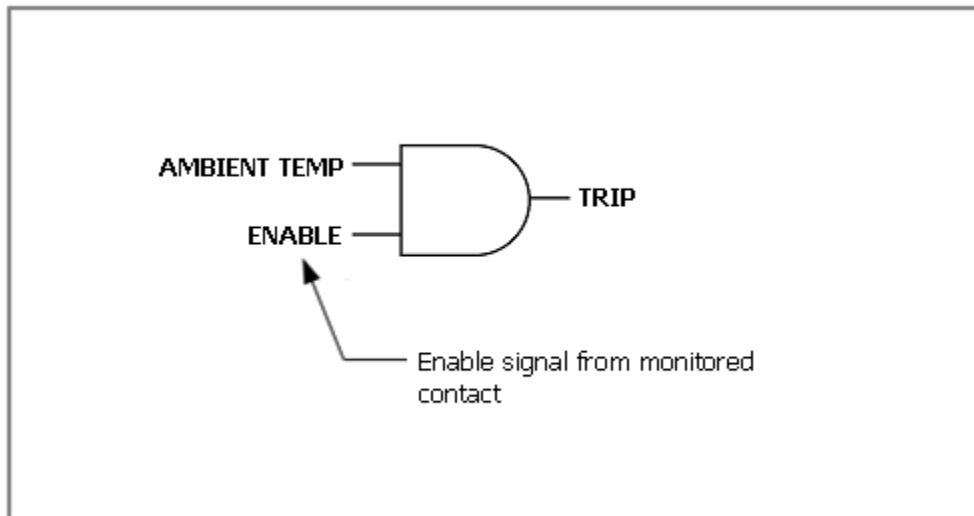

Figure 2: Using the monitored contact status as a logic enable

Conclusion

The RTD inputs of the EPC-2374 can be reliably used to monitor an external contact if configured correctly:

- Connect a 150 ohm resistor across the RTD channel used.
- Connect a 500 ohm resistor across the RTD channel used through the contact as shown in figure 1.
- Configure the set-point manager for a 'trip below' 100 degrees C. Verify the RTD input used is enabled in the set-point manager. A closure of the monitored contact will result in a trip of the RTD channel used.
- Use the output manager to use the RTD input as an input to your logic.

Application note: AN1001 <http://www.microteknix.com/data/an/an1001.pdf>

Additional Information:

Questions & Comments: info@microteknix.com

AN1001 Copyright © by Microteknix LLC 2009

Legal notices: <http://www.microteknix.com/terms.html>